

The 8051 Microcontroller and Embedded Systems

8051 SERIAL PORT PROGRAMMING IN
ASSEMBLY

OBJECTIVES

- Contrast and compare serial versus parallel communication
- List the advantages of serial communication over parallel
- Explain serial communication protocol
- Contrast synchronous versus asynchronous communication
- Contrast half-versus full-duplex transmission
- Explain the process of data framing
- Describe data transfer rate and bps rate
- Define the RS232 standard
- Explain the use of the MAX232 and MAX233 chips

Basics of Serial Communication

- Serial communication is used for transferring data between 2 systems located at distances of hundreds of feet to millions of miles apart.

Serial Transfer



Parallel Transfer

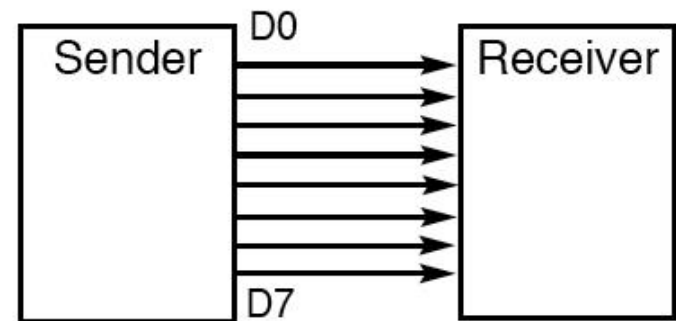

	Serial transmission	Parallel Transmission
Data transfer	1.Data transfer done by bit by bit.	1.Data transfer done by more than 1 bit at a time(8 bit data)
Data Transfer rate	Slower	faster
Wiring requirement	For long distance can be used as single wire required	For long distance can't be used as more wires required
Cost	Low	High

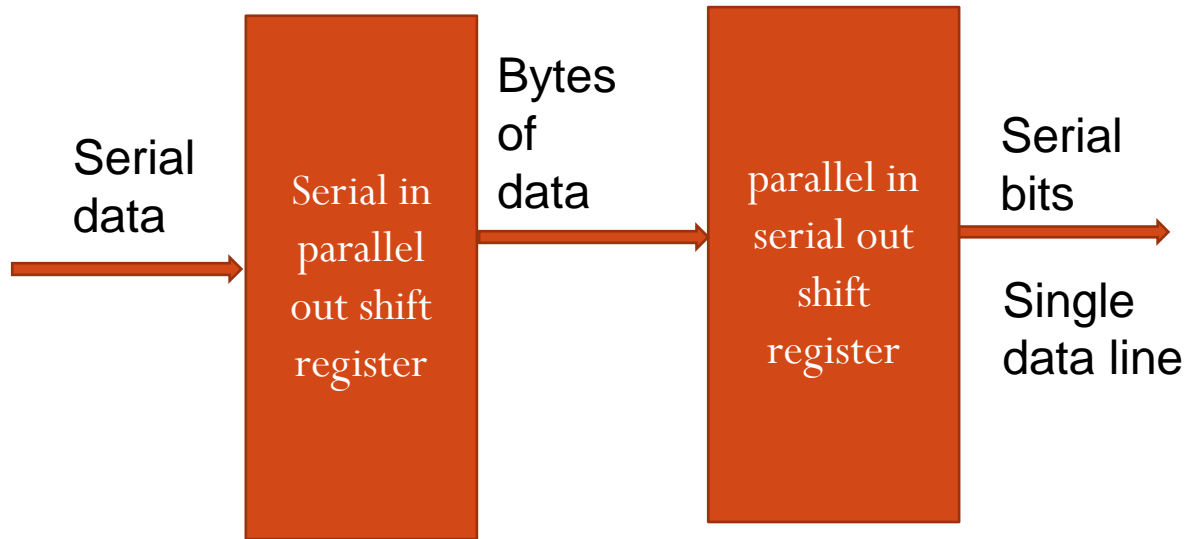

If data is to be transferred on telephone line

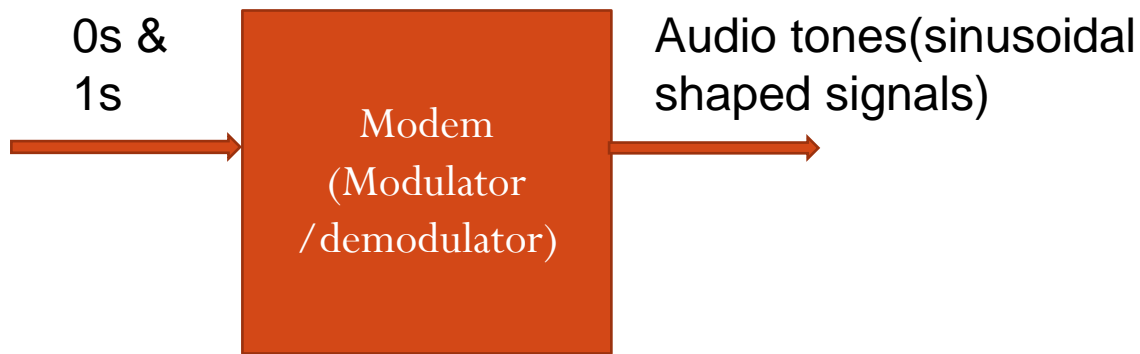

- When distance is short digital signal can be transferred as it is on a single wire & requires no modulation. e.g. IBM PC keyboard transfer data to motherboard.
- For long distance data transfer using communication lines such as telephone, serial data communication requires a modem to modulate(convert from 0s & 1s to audio tones) & demodulate(converting from audio tones to 0s & 1s)

Serial data communication methods

- Synchronous :-transfer block of data (characters) at a time
- Asynchronous:- transfer a single byte at a time
- By Software ,this method programs are tedious & long.

Serial data communication chips

- UART(universal asynchronous receiver transmitter)
- USART(universal synchronous -asynchronous receiver transmitter)
- 8051 has in built UART chip

Simplex



Half Duplex

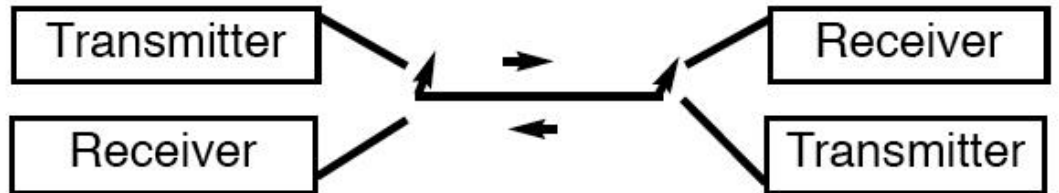

Full Duplex

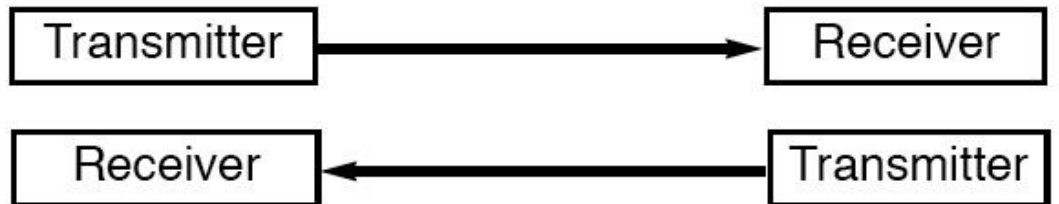

Half duplex & full duplex transmission

- Simplex transmission:-e.g. printers (computer only sends data)

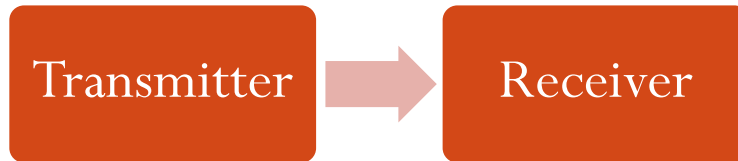

- In data transmission if data can be transmitted & received it is duplex transmission.
- Half duplex :-data is transmitted 1 way at a time.

Half duplex & full duplex transmission

- Full duplex :-data can go both ways at same time.

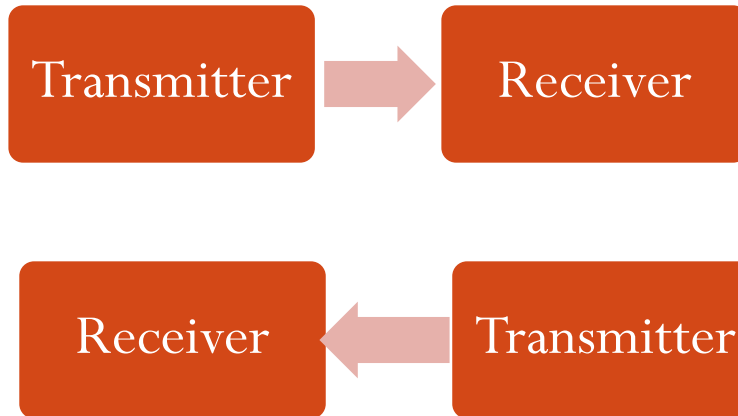

- It requires 2 wire conductors for data lines (in addition to signal ground), 1 for transmission & 1 for reception, in order to transfer & receive data simultaneously.

Port Pin	Alternate Function
P3.0	RXD (serial input port)
P3.1	TXD (serial output port)
P3.2	$\overline{\text{INT0}}$ (external interrupt)
P3.3	$\overline{\text{INT1}}$ (external interrupt)
P3.4	T0 (Timer/Counter 0 external input)
P3.5	T1 (Timer/Counter 1 external input)
P3.6	$\overline{\text{WR}}$ (external data memory write strobe)
P3.7	$\overline{\text{RD}}$ (external data memory read strobe)

SECTION 10.1: BASICS OF SERIAL COMMUNICATION

- **Asynchronous serial communication and data framing**
 - data coming in 0s and 1s
 - to make sense of the data sender and receiver agree on a set of rules
 - **Protocol**
 - how the data is packed
 - how many bits/character
 - when the data begins and ends

SECTION 10.1: BASICS OF SERIAL COMMUNICATION

- **Start and stop bits**
 - asynchronous method, each character is placed between start and stop bits
 - called *framing*
 - start bit is always one bit
 - stop bit can be one or two bits
 - start bit is always a 0 (low)
 - stop bit(s) is 1 (high)
 - LSB is sent out first

SECTION 10.1: BASICS OF SERIAL COMMUNICATION

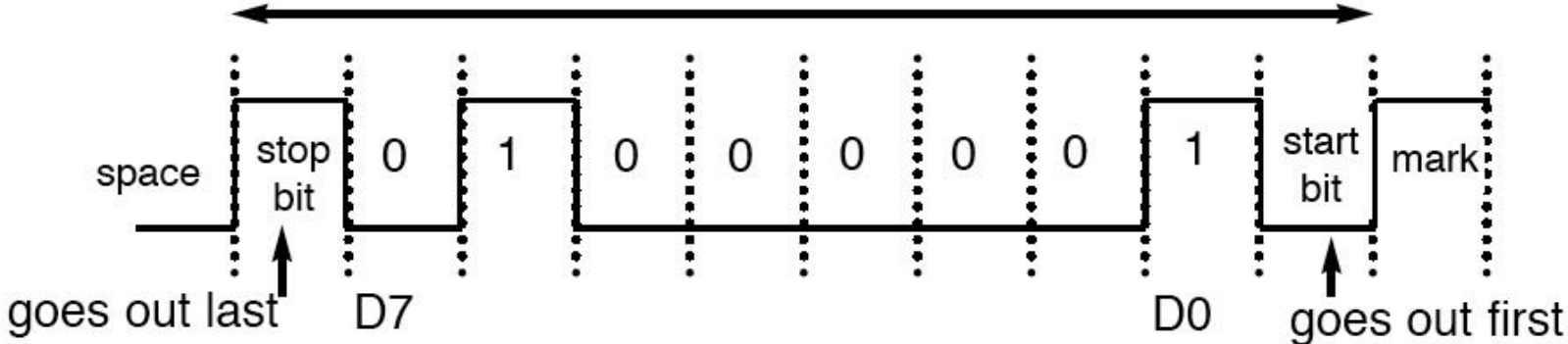

Figure 10-3 Framing ASCII "A" (41H)

SECTION 10.1: BASICS OF SERIAL COMMUNICATION

- **in modern PCs one stop bit is standard**
- **when transferring a text file of ASCII characters using 1 stop bit there is total of 10 bits for each character**
- **8 bits for the ASCII code (1 parity bit), 1 bit each for the start and stop bits**
- **for each 8-bit character there are an extra 2 bits, which gives 20% overhead**

SECTION 10.1: BASICS OF SERIAL COMMUNICATION

- **Data transfer rate**
 - rate of data transfer *bps* (bits per second)
 - widely used terminology for *bps* is *baud rate*
 - baud and *bps* rates are not necessarily equal
 - baud rate is defined as the number of signal changes per second

9-Pin Connector

Pin	Description
1	Data carrier detect ($\overline{\text{DCD}}$)
2	Received data (RxD)
3	Transmitted data (TxD)
4	Data terminal ready (DTR)
5	Signal ground (GND)
6	Data set ready ($\overline{\text{DSR}}$)
7	Request to send ($\overline{\text{RTS}}$)
8	Clear to send ($\overline{\text{CTS}}$)
9	Ring indicator (RI)

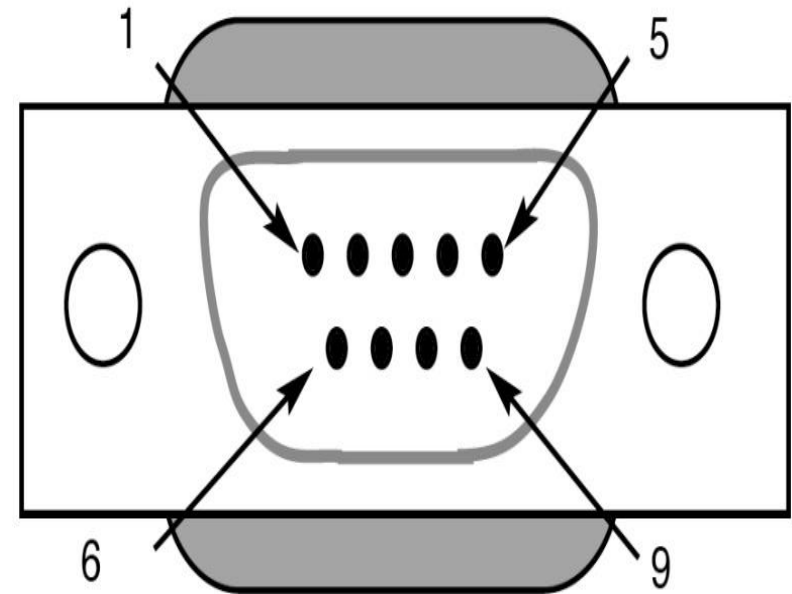

DB-9 9-Pin Connector

Data communication classification

- **Data communication classification**
 - **DTE (data terminal equipment)**
 - **DCE (data communication equipment)**
 - **DTE - terminals and computers that send and receive data**
 - **DCE - communication equipment responsible for transferring the data**
 - **simplest connection between a PC and microcontroller requires a minimum of three pins, TxD, RxD, and ground**

DB-9 9-Pin Connector

- **1.DTR(data terminal ready)**:-When a terminal (PC com port)is turned on, it sends signal DTR to indicate that it is ready for communication.
- **2.DSR(Data set ready)** :-When DCE(data communication equipment)i.e. modem is on,DSR indicate that it is ready to communicate. Active low signal.
- **3.RTS(Request to send)**:-When DTE(data terminal equipment)(PC)has byte to transmit, RTS send the signal to the modem that it has a byte of data to trasmit.Active low .
- **4. CTS(clear to send)**:-modem sends CTS signal to DTE(PC)to indicate that it can receive data now.

DB-9 9-Pin Connector

- **5.DCD(Carrier detect or data carrier detect)**:-Modem sends DCD signal to inform DTE(PC)that valid carrier is detected & that contact between it & other modem is established.
- **6.RI(ring indicator)**:-An o/p from modem(DCE)& i/p to PC(DTE) indicates that telephone is ringing.

Null Modem Connection

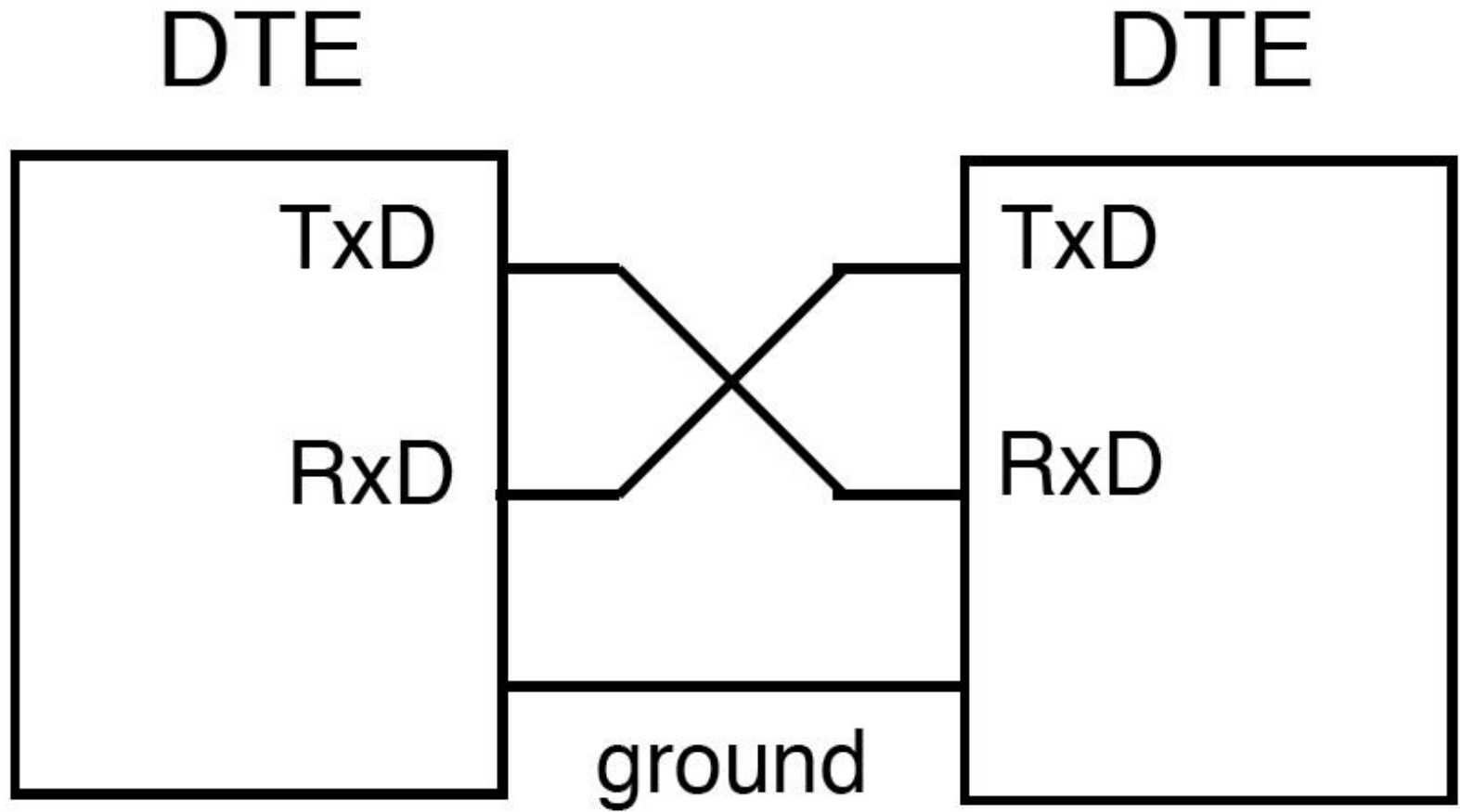

Figure 10-6 Null Modem Connection

SECTION 10.2: 8051 CONNECTION TO RS232

- **RxD and TxD pins in the 8051**
 - 8051 has two pins used for transferring and receiving data serially
 - TxD and RxD are part of the port 3 group
 - pin 11 (P3.1) is assigned to TxD
 - pin 10 (P3.0) is designated as RxD
 - these pins are TTL compatible
 - require a line driver to make them RS232 compatible
 - driver is the MAX232 chip

SECTION 10.2: 8051 CONNECTION TO RS232

- **MAX232 (Line Driver) (voltage converter)**
 - converts from RS232 voltage levels to TTL voltage levels
 - uses a +5 V power source
 - MAX232 has two sets of line drivers for transferring and receiving data
 - line drivers used for TxD are called T1 and T2
 - line drivers for RxD are designated as R1 and R2
 - T1 and R1 are used together for TxD and RxD of the 8051
 - 4 capacitors used(1 to 22 UF)

SECTION 10.2: 8051 CONNECTION TO RS232

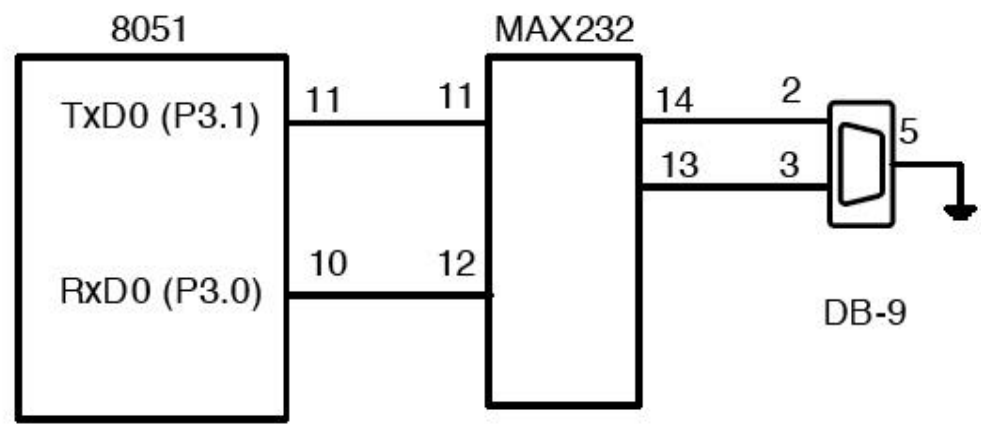
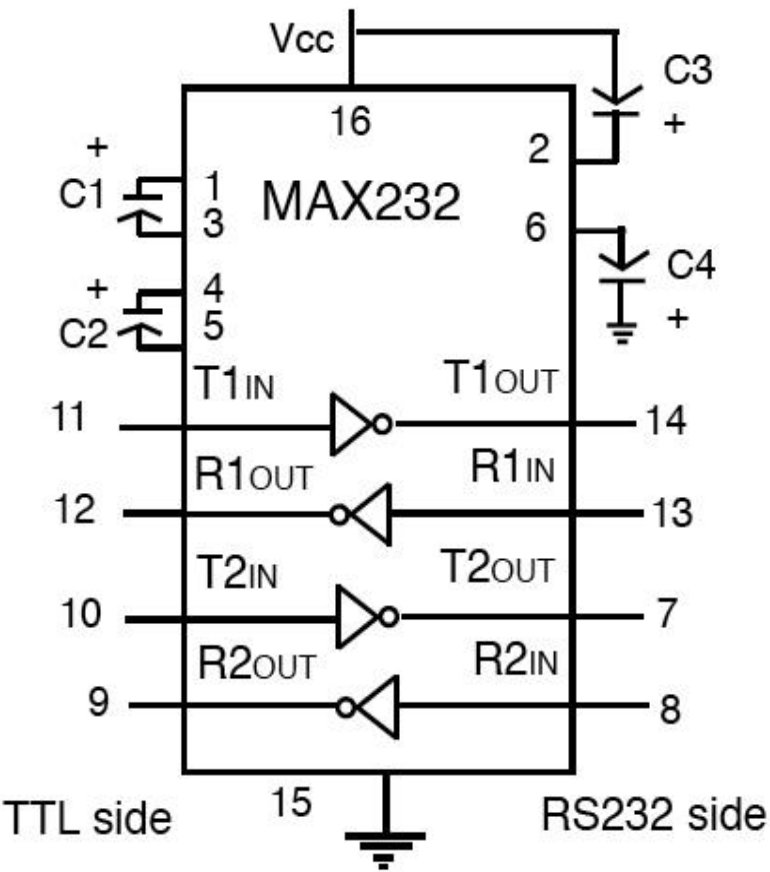

Figure 10-7

(a) Inside MAX232
 (b) its Connection to the 8051 (Null Modem)

SECTION 10.2: 8051 CONNECTION TO RS232

- **MAX233**
 - **MAX233 performs the same job as the MAX232**
 - **eliminates the need for capacitors**
 - **much more expensive than the MAX232**

SECTION 10.2: 8051 CONNECTION TO RS232

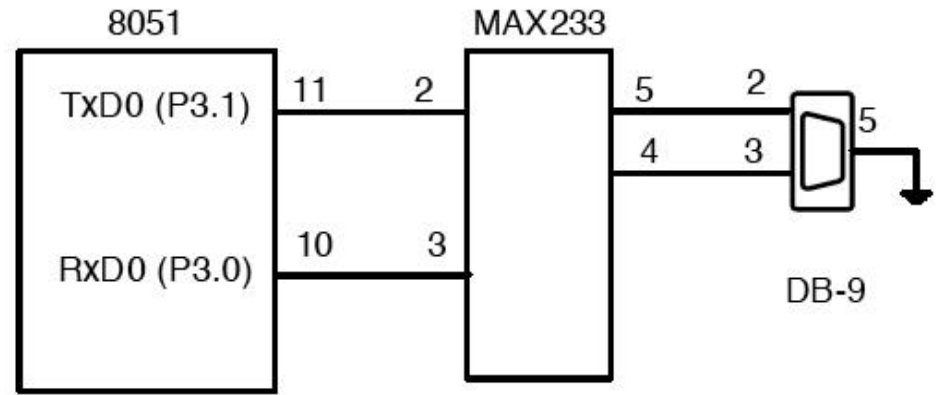
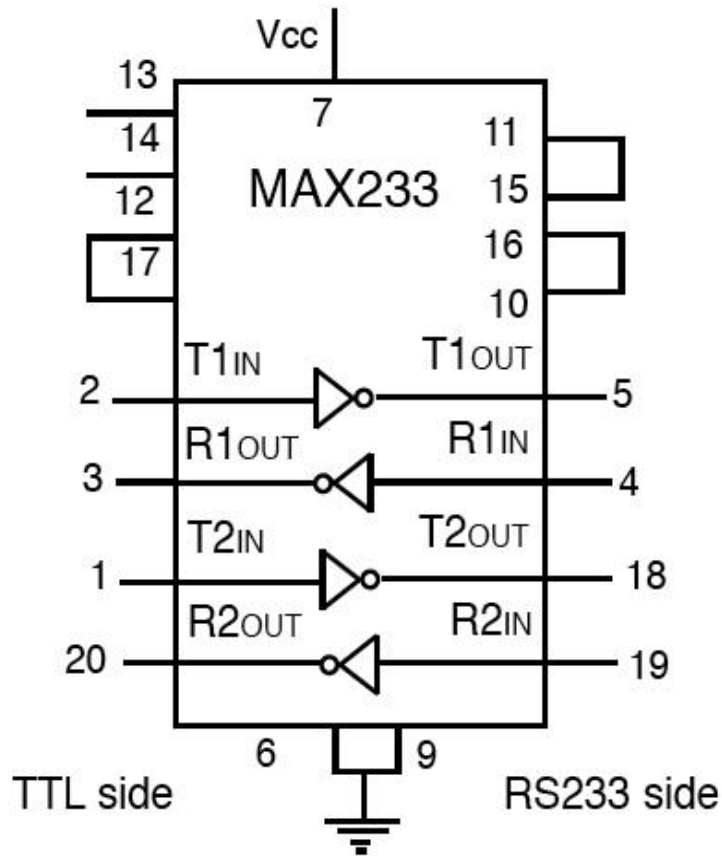

Figure 10-8

(a) Inside MAX233

(b) Its Connection to the 8051 (Null Modem)

Baud rate in the 8051

- **Baud rate in the 8051**
 - serial communications of the 8051 with the COM port of the PC
 - To allow data transfer between PC & 8051 w/o error, we must make sure that the baud rate of the 8051 system matches the baud rate of the PC's COM port.
 - can use Windows HyperTerminal program

PC Baud Rates

110

150

300

600

1200

2400

4800

9600

19200

Note: Some of the Baud rates supported by 486/Pentium IBM PC BIOS.

Baud rate in the 8051

- baud rate in the 8051 is programmable
- done with the help of **Timer 1**
- relationship between the crystal frequency and the baud rate in the 8051
- 8051 divides the crystal frequency by 12 to get the machine cycle frequency
- XTAL = 11.0592 MHz, the machine cycle frequency is 921.6 kHz
- 8051's UART divides the machine cycle frequency of 921.6 kHz by 32 once more before it is used by Timer 1 to set the baud rate
- 921.6 kHz divided by 32 gives 28,800 Hz
- Timer 1 must be programmed in mode 2, that is 8-bit, auto-reload

Timer 1 TH1 Register Values for Various Baud Rates

Baud Rate	TH1 (Decimal)	TH1 (Hex)
9600	-3	FD
4800	-6	FA
2400	-12	F4
1200	-24	E8

Note: XTAL = 11.0592 MHz.

Table 10-4 Timer 1 TH1 Register Values for Various Baud Rates

Example 10-1

With XTAL = 11.0592 MHz, find the TH1 value needed to have the following baud rates. (a) 9600 (b) 2400 (c) 1200

- **machine cycle frequency**
 $= 11.0592 \text{ MHz} / 12 = 921.6 \text{ kHz}$
- **Timer 1 frequency provided by 8051 UART**
 $= 921.6 \text{ kHz} / 32 = 28,800 \text{ Hz}$

- | | | |
|--------------------------|-----------|------------|
| (a) $28,800 / 3 = 9600$ | where -3 | = FD (hex) |
| (b) $28,800 / 12 = 2400$ | where -12 | = F4 (hex) |
| (c) $28,800 / 24 = 1200$ | where -24 | = E8 (hex) |

SECTION 10.3: 8051 SERIAL PORT PROGRAMMING IN ASSEMBLY

11.0592 MHz

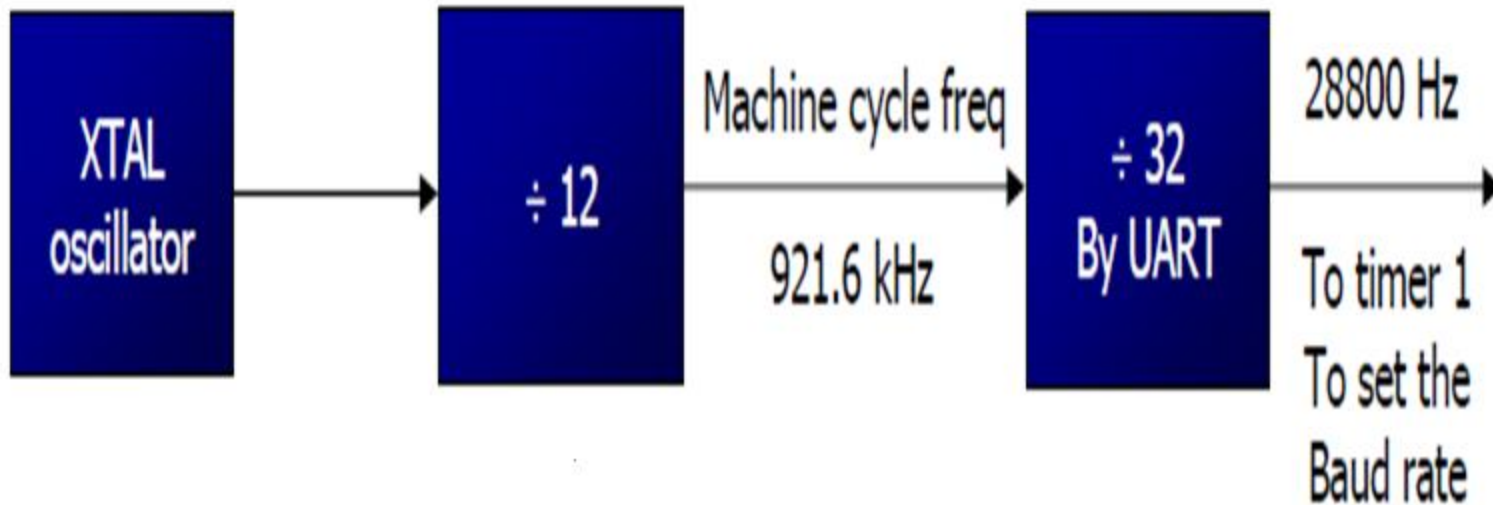

SBUF (serial buffer) register (8 bit)

- a byte of data to be transferred via the TxD line must be placed in the SBUF register
- SBUF holds the byte of data when it is received by the RxD line
- can be accessed like any other register
 - MOV SBUF,# 'D' ;load SBUF=44H, ASCII for 'D'
 - MOV SBUF,A ;copy accumulator into SBUF
 - MOV A,SBUF ;copy SBUF into accumulator
- when a byte is written, it is framed with the start and stop bits and transferred serially via the TxD pin
- when the bits are received serially via RxD, it is deframe by eliminating the stop and start bits, making a byte out of the data received, and then placing it in the SBUF .

Serial Control Register (SCON)

Bit 7

Bit 0

SM0	SM1	SM2	RE	TB8	RB8	TI	RI
-----	-----	-----	----	-----	-----	----	----

Bit	Operation				
	Serial communication mode selection bits				
	SM0	SM1	Mode	Description	Baud rate
SM0	0	0	Mode 0	8 bit shift register mode	$f_{osc}/12$
	0	1	Mode 1	8 bit UART	variable (set by timer 1)
SM1	1	0	Mode 2	9 bit UART	$f_{osc}/32$ or $f_{osc}/64$
	1	0	Mode 3	9 bit UART	variable (set by timer 1)
SM2	In mode 2 and 3, if set, this will enable multiprocessor communication (Always 0)				
REN	Set/cleared by s/w to enable/disable serial reception(Receive enable)				
TB8	Transfer bit 8,Used in serial mode 2 and 3 (Not used ,Always 0)				
RB8	Receive bit 8,Used in serial mode 2 and 3 (Not used ,Always 0) In mode 1, if SM2=0, then RB8 is the stop bit that is received				
TI	Transmit interrupt flag, set by hardware must be cleared by software				
RI	Receive interrupt flag, set by hardware must be cleared by software				

Serial Control Register (SCON)

- SM0 and SM1 determine the mode
- only mode 1 is important
- when mode 1 is chosen, the data framing is 8 bits, 1 stop bit, and 1 start bit
- compatible with the COM port of PCs
- mode 1 allows the baud rate to be variable and is set by Timer 1 of the 8051
- for each character a total of 10 bits are transferred, where the first bit is the start bit, followed by 8 bits of data, and finally 1 stop bit.

Serial Control Register (SCON)

- REN (receive enable)
- REN=1, allows 8051 to receive data on the RxD
- if 8051 is to both transfer and receive data, REN must be set to 1
- REN=0, the receiver is disabled
- SETB SCON.4 and CLR SCON.4,

Serial Control Register (SCON)

- TI (transmit interrupt)
 - when 8051 finishes the transfer of the 8-bit character, it raises the TI flag to indicate that it is ready to transfer another byte
- RI (receive interrupt)
 - when the 8051 receives data serially via RxD, it places the byte in the SBUF register
 - then raises the RI flag bit to indicate that a byte has been received and should be picked up before it is lost

Programming 8051 to transfer data serially

1. TMOD register is loaded with the value 20H i.e. Timer 1 in mode 2
2. TH1 is loaded with value to set the baud rate
3. SCON register is loaded with the value 50H i.e. serial mode 1 & 8 bit data framed with start & stop bits.
4. TR1 is set to 1 to start Timer1
5. TI is cleared by the “CLR TI” instruction
6. transmit character byte is written into the SBUF register
7. TI flag bit is monitored with use of instruction “JNB TI,XX” to see if the character has been transferred completely
8. to transfer the next character, go to Step 5.

Example 10-2

Write a program to transfer letter "A" serially at 4800 baud, continuously.

```
01 MOV TMOD,#20H           ;Timer 1, mode 2(auto-reload)
02 MOV TH1,#-6            ;4800 baud rate
03 MOV TCON,#50H         ;8-bit, 1 stop, REN enabled
04 SETB TR1              ;start Timer 1
05 AGAIN: MOV SBUF,#"A"   ;letter "A" to be transferred
06 HERE: JNB TI,HERE      ;wait for the last bit
07 CLR TI                 ;clear TI for next char
08 SJMP AGAIN            ;keep sending A
09
10 END
```

Example 10-3

Write a program to transfer the message "YES" serially at 9600 baud, 8-bit data, 1 stop bit. Do this continuously.

```
01 MOV TMOD,#20H           ;Timer 1 Mode 2
02 MOV TH1,#-3            ;9600 baud
03 MOV TCON,#50H         ;8-bit, 1 stop bit, REN enabled
04 SETB TR1              ;start Timer 1
05 AGAIN: MOV A,#"Y"      ;transfer "Y"
06 ACALL TRANS
07 MOV A,#"E"            ;transfer "E"
08 ACALL TRANS
09 MOV A,#"S"            ;transfer "S"
10 ACALL TRANS
11 SJMP AGAIN            ;keep doing it
12 ;-----
13 ;serial data transfer subroutine
14 ;-----
15 TRANS: MOV SBUF,A      ;load SBUF
16 HERE: JNB TI,HERE      ;wait for last bit to transfer
17 CLR TI                 ;get ready for next byte
18 RET
19
20 END
```

SECTION 10.3: 8051 SERIAL PORT PROGRAMMING IN ASSEMBLY

- **Importance of the TI flag**
 - **check the TI flag bit, we know whether can transfer another byte**
 - **TI flag bit is raised by the 8051**
 - **TI flag cleared by the programmer**
 - **writing a byte into SBUF before the TI flag bit is raised, may lead to loss of a portion of the byte being transferred**

Programming 8051 to receive data serially

1. TMOD register is loaded with the value 20H i.e. Timer 1 in mode 2
2. TH1 is loaded with value to set the baud rate
3. SCON register is loaded with the value 50H i.e. serial mode 1 & 8 bit data framed with start & stop bits & RI=ON
4. TR1 is set to 1 to start Timer1
5. RI is cleared by the “CLR RI” instruction
6. RI flag bit is monitored with use of instruction “JNB RI,XX” to see if the character has been received yet.
7. When RI is raised,SBUF has byte. Its content moved to safe place.
8. to receive the next character, go to Step 5.

Example 10-4

Program the 8051 to receive bytes of data serially, and put them in P1. Set the baud rate at 4800, 8-bit data, and 1 stop bit.

```
01 MOV TMOD,#20H      ;Timer 1, mode 2 (auto reload)
02 MOV TH1,#-6       ;4800 baud
03 MOV TCON,#50H     ;8-bit, 1 stop, REN enabled
04 SETB TR1         ;start Timer 1
05 HERE: JNB RI,HERE ;wait for char to come in
06 MOV A,SBUF       ;save incoming byte in A
07 MOV P1,A        ;send to port 1
08 CLR RI          ;get ready to receive next byte
09 SJMP HERE       ;keep getting data
10
11 END
```

SECTION 10.3: 8051 SERIAL PORT PROGRAMMING IN ASSEMBLY

- **Importance of the RI flag bit**
 1. it receives the start bit, next bit is the first bit of the character
 2. when the last bit is received, a byte is formed and placed in SBUF
 3. when stop bit is received, makes $RI = 1$
 4. when $RI=1$, received byte is in the SBUF register, copy SBUF contents to a safe place
 5. after the SBUF contents are copied the RI flag bit must be cleared to 0

Doubling Baud Rate

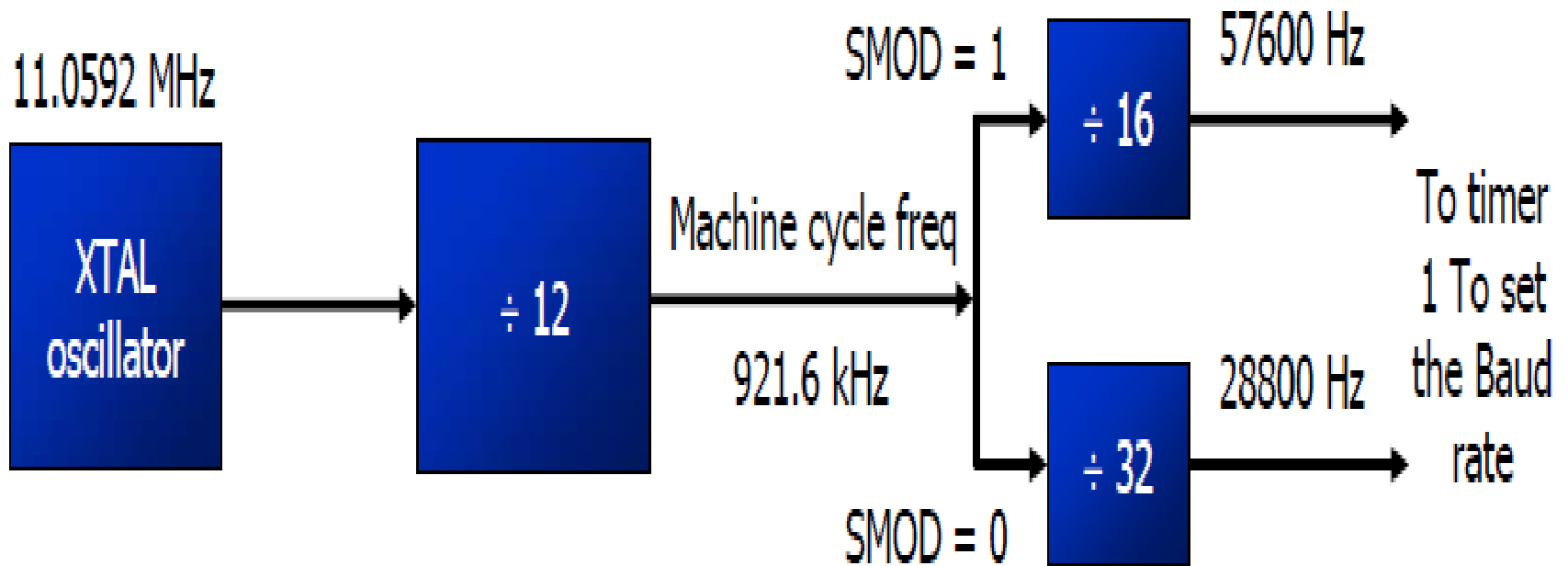

Baud Rate comparison for SMOD=0 and SMOD=1

TH1	(Decimal)	(Hex)	SMOD=0	SMOD=1
-3		FD	9600	19200
-6		FA	4800	9600
-12		F4	2400	4800
-24		E8	1200	2400

- If the crystal frequency is 22 MHz, what will be baud rate if :
(a) TH1=-3; (b) TH1=-12 with SMOD =0 & SMOD =1

Solution:-

With SMOD =0, Machine Cycle freq. = $22/12 = 1833$ KHz
& $1833/32 = 57.281$ KHz = 57,281

- (a) With TH1 =-3, baud rate = $57,281/3 = 19,093$
- (b) With TH1 =-12, baud rate = $57,281/12 = 4773$

With SMOD =1, baud rate are doubled

- (a) With TH1 =-3, baud rate = 38,186
- (b) With TH1 =-12, baud rate = 9546

- Find the baud rate if $TH1 = -2$, $SMOD = 1$, and $XTAL = 11.0592$ MHz. Is this baud rate supported by IBM compatible PCs?

Solution:

With $XTAL = 11.0592$ and $SMOD = 1$, we have timer frequency = 57,600 Hz. The baud rate is $57,600/2 = 28,800$. This baud rate is not supported by the BIOS of the PCs; however, the PC can be programmed to do data transfer at such a speed. Also, HyperTerminal in Windows supports this and other baud rates.